

4

3

2

1

B

B

A

A

A

A

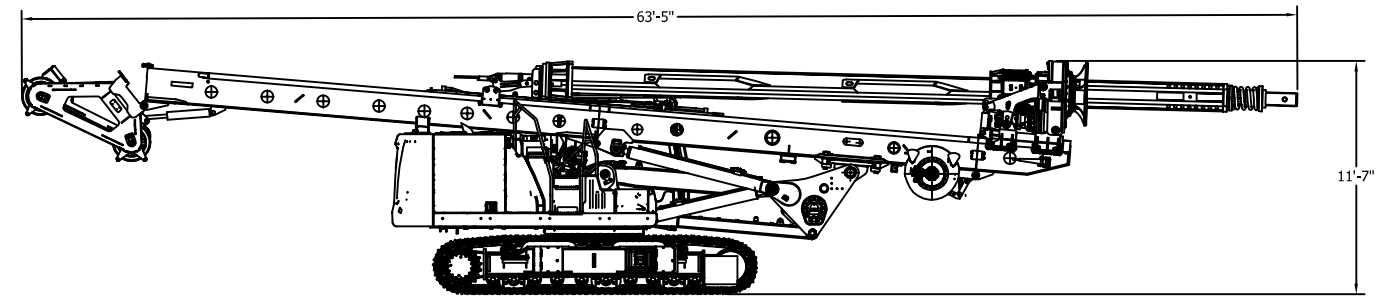
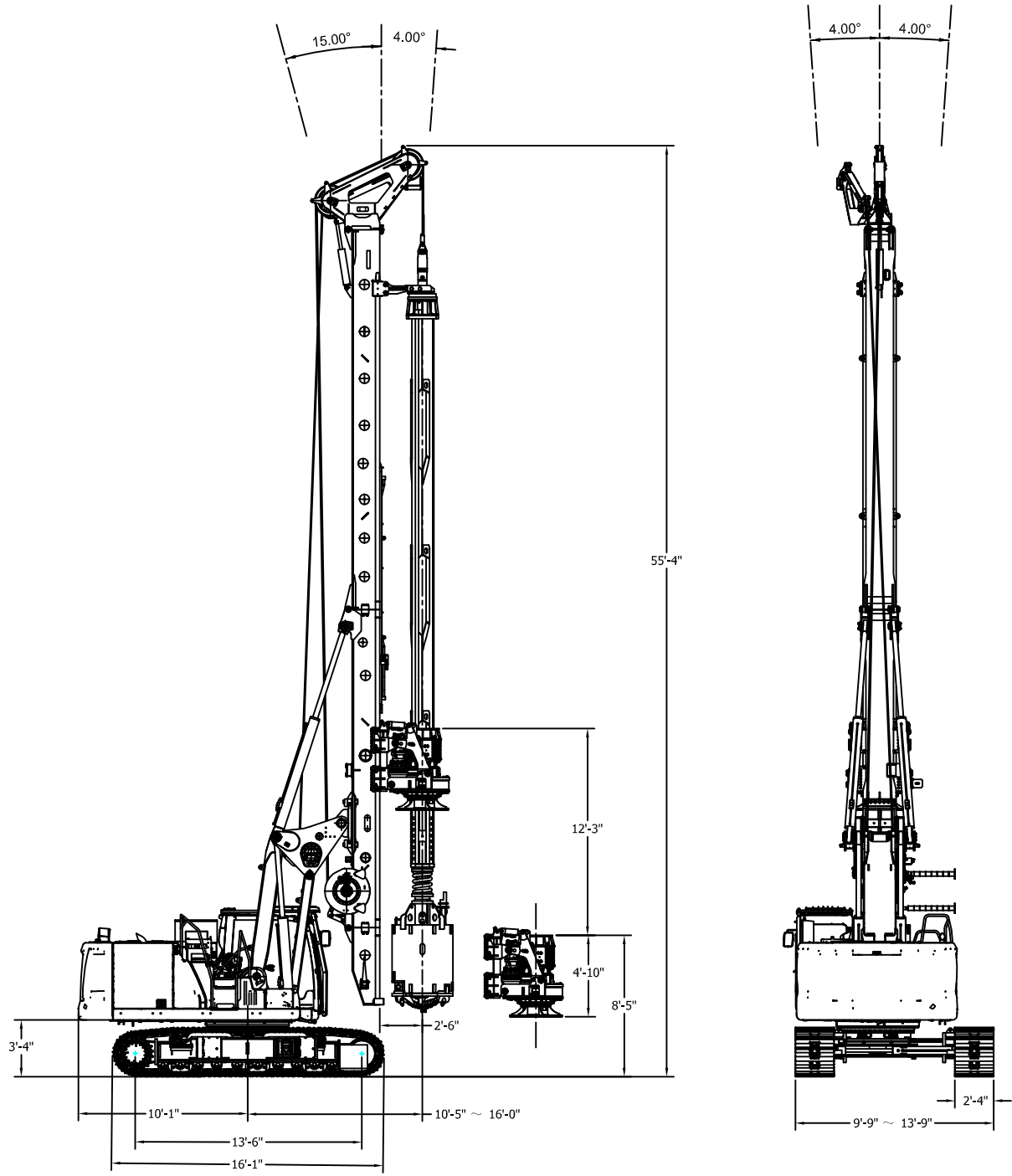

TRANSPORT WEIGHT 109,000 LBS WITH KELLY BAR
 TRANSPORT WEIGHT 95,800 LBS W/O KELLY BAR

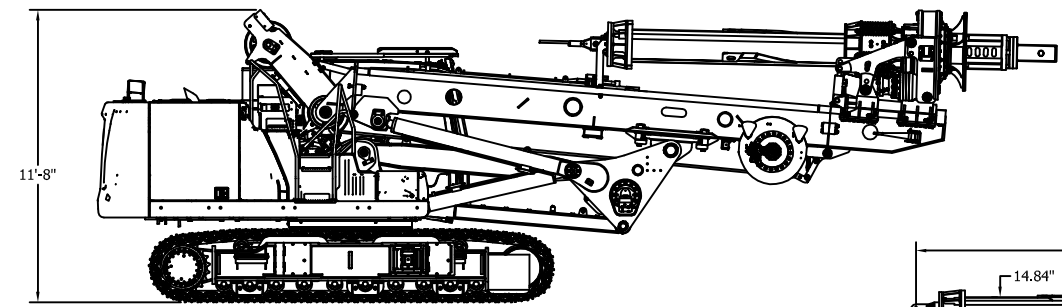

TRANSPORT WEIGHT WITH KELLY BAR 99,000 LBS
 TRANSPORT WEIGHT W/O KELLY BAR 92,400 LBS

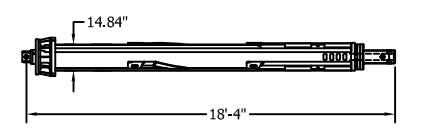

4 - ELEMENT LOCKING BAR
 TRANSPORT WEIGHT 6,600 LBS

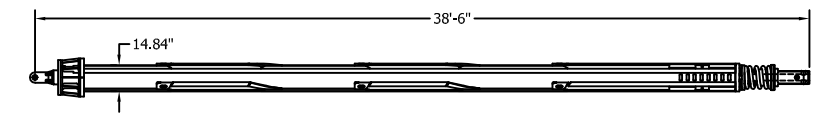

4 - ELEMENT LOCKING BAR
 TRANSPORT WEIGHT 13,200 LBS

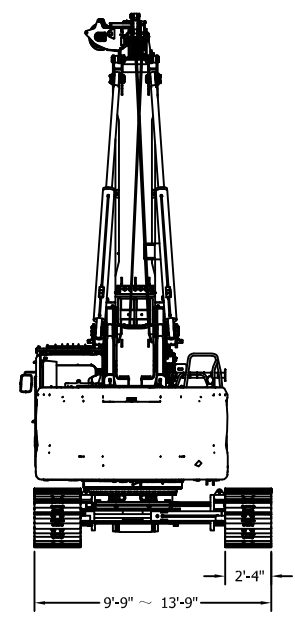
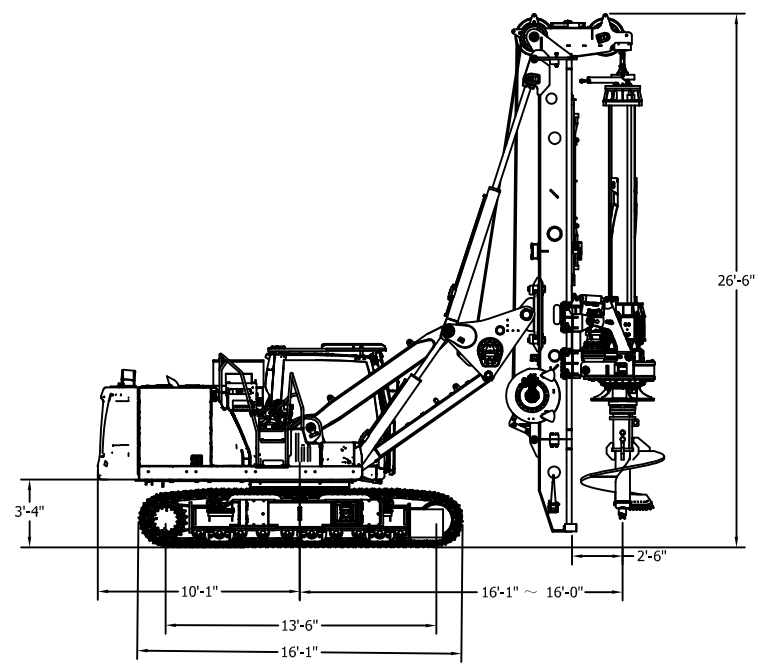

| SPECIFICATIONS | | |
|-------------------------------|---------|--------------|
| ENGINE CAT C7.1 Tier 4 Final | (hp) | 275 |
| TORQUE | (ft/lb) | 132,761 |
| ROTARY SPEED | (rpm) | 6-32 |
| CROWD FORCE DOWN | (lb) | 40,466 |
| CROWD FORCE UP | (lb) | 40,466 |
| MAIN WINCH | (lb) | 35,969 |
| MAIN WINCH WIRE ROPE | (mm) | 26 |
| AUXILIARY WINCH | (lb) | 11,124 |
| WORKING HEIGHT STANDARD MAST | (ft) | 55'-4" |
| DRILL DEPTH STANDARD MAST | (ft) | 120'-0" |
| WORKING HEIGHT SHORT MAST | (ft) | 26'-6" |
| DRILL DEPTH SHORT MAST | (hp) | 52'-6" |
| TRACK WIDTH | (in) | 28" |
| CHASSIS WIDTH TRNSPRT/WORKING | (ft) | 9'-9"/13'-9" |
| TOOL DIAMETER | (ft) | 59" |
| WEIGHT STANDAR MAST w KELLY | (lb) | 109,000 |
| WEIGHT SHORT MAST w KELLY | (lb) | 99,000 |

- SPECIAL FEATURES**
- 1) U.S. MANUFACTURED CAT 330NG EXCAVATOR BASE
 - 2) ELECTRIC OVER HYDRAULIC CONTROL SYSTEM W AUXILIARY CONTROL LEVERS (PILOT OPERATED)
 - 3) SINGLE LOAD TRANSPORT

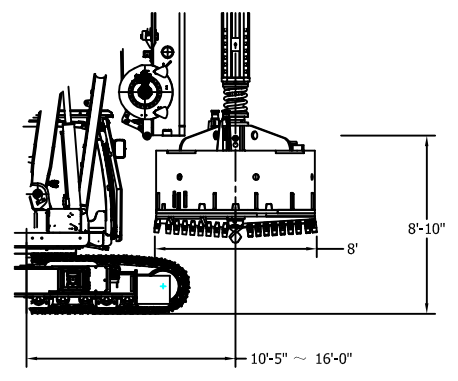
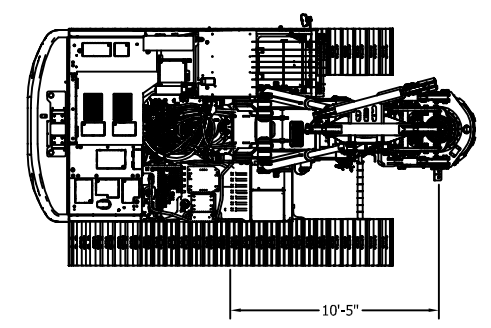

TOOL CLEARANCE W/O MAST FOOT
 AND SHORT KELLY BAR

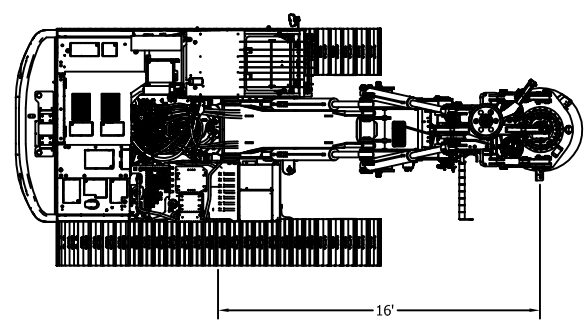

| | |
|----------|-----------|
| DRAWN | 8/27/2020 |
| CHECKED | |
| QA | |
| MFG | |
| APPROVED | |

A. H. Beck Foundation Co., Inc.
 Converse, Texas 78109 210-342-5261

BECK MODEL 180

| | | |
|-------|-------------------|-----|
| SIZE | DWG NO | REV |
| B | MODEL180/330NG.00 | A |
| SCALE | SHEET 1 OF 1 | |

4

3

2

1

B

B

A

A

A

A